



# C1448 - 1400lb Cube Ice Machine

Prodigy Plus® Modular Cube Ice Machine

## The world's smartest cuber.

As the world's only self-monitoring cuber, the new Scotsman Prodigy Plus® cube ice machines make it easier than ever to maintain your equipment and save money. Whether it's the advanced ice level control or an optional feature board for quick diagnostics, this is ice-making re-imagined. And with intuitive technology like AutoAlert™ indicator lights, a reduced operational footprint and easy-access service from the front panel, Prodigy Plus® cubers are simply the smartest, most reliable way to create fresh-tasting ice — every time.

## The Prodigy Plus® difference.

- AutoAlert™ indicator lights for better visibility
- Operational footprint among the industry's smallest
- Industry-exclusive QR code instantly connects users to service information and warranty history
- One-touch cleaning reduces labor costs and saves time
- Front-located air filter for more efficient operation
- Self-aligning front panel for easy access to key components
- Patented WaterSense purge control automatically reduces scale buildup
- Patented Harvest Assist efficiently moves cube ice to the bin
- Smart-Board™ advanced feature module available for additional diagnostic capabilities
- Optional Vari-Smart™ ice level control allows operators to customize ice levels
- Antimicrobial protection guards internal surfaces between cleanings
- A full range of water- and energy-saving features



B948S



BH1100BB  
BH1100SS



BH1300BB  
BH1300SS



## 24 Hour Volume Production

Air Cooled		Remote		Water Cooled	
70°F/21°C 50°F/10°C	Air Water	90°F/32°C 70°F/21°C	70°F/21°C 50°F/10°C	Air Water	90°F/32°C 70°F/21°C
1553/706 lb/kg		1296/589 lb/kg	1357/617 lb/kg		1444/656 lb/kg
			1258/572 lb/kg		1340/609 lb/kg



## Modular Bin Options

Model Number*	Dimensions W" x D" x H"	Bin Application		Ship Weight lb/kg
		Capacity lb/kg	Finish	
B948S	48 x 34 x 44**	893/406	Metallic	209/95
BH1100BB	48 x 34 x 50**	1100/499	SS w/ GBB†	280/127
BH1100SS	48 x 34 x 50**	1100/499	Stainless Steel	280/127
BH1300BB	60 x 34 x 50**	1400/635	SS w/ GBB†	310/141
BH1300SS	60 x 34 x 50**	1400/635	Stainless Steel	310/141

\* Contact Scotsman for bin top requirements. \*\* Add 6" Height for bin legs.  
† Stainless steel with galvanized back & bottom.



## Cube Ice

Common ice form, ideal for mixed drinks.



Small Cube  
7/8" x 7/8" x 3/8"  
(2.22 x 2.22 x .95 cm)



Medium Cube  
7/8" x 7/8" x 7/8"  
(2.22 x 2.22 x 2.22 cm)



## Certification



## Warranty

- 3 years parts and labor on all components.
- 5 years parts and labor on the evaporator.
- 5 years parts on the compressor and condenser.
- Warranty valid in North, South & Central America for commercial installations.
- Contact factory for warranty in other regions.
- Residential Applications: 1 year parts and labor

C1448 - 1400lb Cube Ice Machine



# C1448 - 1400lb Cube Ice Machine

## Prodigy Plus® Modular Cube Ice Machine

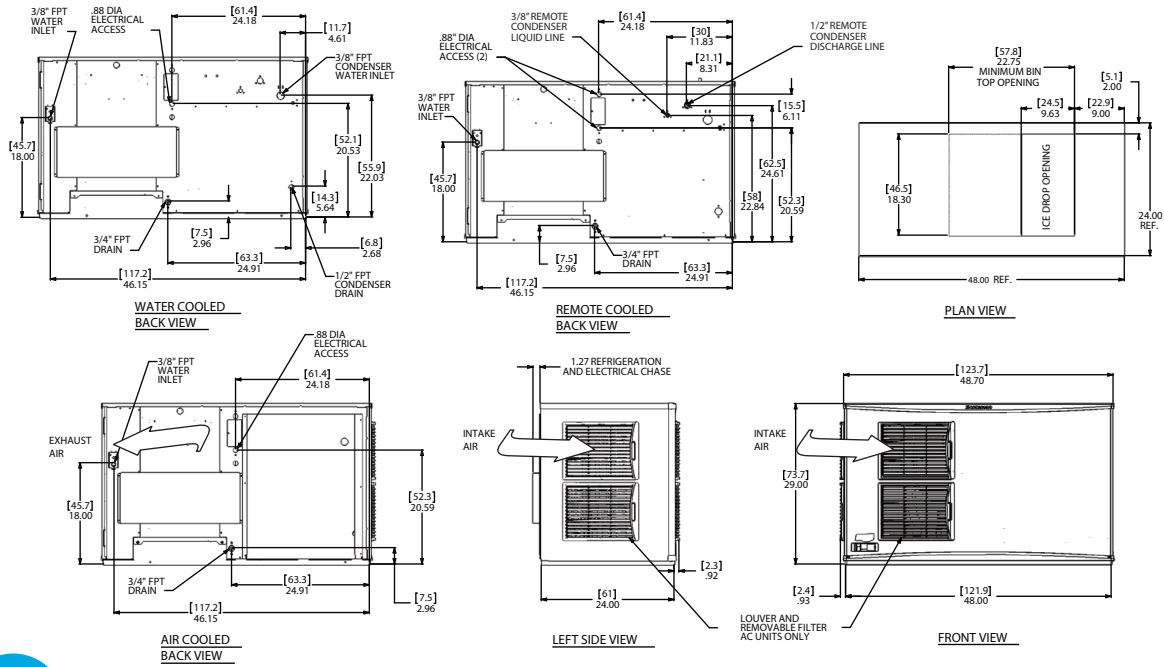

### Specifications

Model Number*	Condenser Unit	Basic Electrical Volts/Hz/Phase	Max. Fuse Size or HACR Circuit Breaker (amps)	Circuit Wires	Min. Circuit Ampacity	Energy Consumption kWh/100 lb (45.4 kg) 90°F(32°C)/70°F(21°C)	Water Usage Gallons/100 lb (liters/45.4 kg)		Energy Star®	
							Potable 90°F(32°C)/70°F(21°C)	Condenser 90°F(32°C)/70°F(21°C)		
-med-	C1448MA-32	Air	208-230/60/1	30	2	17.7	4.25	18.0/68.3	-	✓
	C1448MA-3	Air	208-230/60/3	30	3	13.6	4.25	18.0/68.3	-	✓
	C1448MR-32	Remote	208-230/60/1	30	2	17.0	4.34	18.0/68.3	-	
	C1448MR-3	Remote	208-230/60/3	30	3	12.9	4.34	18.0/68.3	-	
	C1448MW-32	Water	208-230/60/1	30	2	16.0	3.70	18.0/68.3	100.0/379.5	
	C1448MW-3	Water	208-230/60/3	30	3	11.9	3.70	18.0/68.3	100.0/379.5	
-us-	C1448SA-32	Air	208-230/60/1	30	2	17.7	4.25	18.0/68.3	-	✓
	C1448SA-3	Air	208-230/60/3	30	3	13.6	4.25	18.0/68.3	-	✓
	C1448SR-32	Remote	208-230/60/1	30	2	17.0	4.34	18.0/68.3	-	
	C1448SR-3	Remote	208-230/60/3	30	3	12.9	4.34	18.0/68.3	-	
	C1448SW-32	Water	208-230/60/1	30	2	16.0	3.70	18.0/68.3	100.0/379.5	
	C1448SW-3	Water	208-230/60/3	30	3	11.9	3.70	18.0/68.3	100.0/379.5	



### All Models

#### Dimensions (W x D x H):

Unit: 48" x 24" x 29"  
(121.9 x 61.0 x 73.7 cm)

Shipping Carton: 52" x 27" x 35"  
(132.1 x 68.6 x 88.9 cm)

Shipping Weight: 345 lb / 157 kg

BTUs per hour: 20,000

Refrigerant: R-404A



### Accessories

Model Number	Description
KVS	Vari-Smart™ Ice Level Control - Program ice bin levels to match ice needs.
KSBU	Smart-Board™ Advanced Control - Use additional operational data for fast diagnosis.
KSBU-N	Smart-Board™ Advanced Control with Network - Network capable.
ERC311-32	Remote condenser for C1448xR, 208-230/60/1 - Consult remote condenser spec sheet for details
BRTE10	10ft (3.0 m) line set, brazing required
BRTE25	25ft (7.6 m) line set, brazing required
BRTE40	40ft (12.2 m) line set, brazing required
BRTE75	75ft (22.9 m) line set, brazing required
KPAS	Prodigy Advanced Sustainability Kit - Includes KVS and KSBU - N

Scotsman recommends all ice machines have water filtration. See Scotsman water filter specification sheet for details.



### Operating Requirements

	Minimum	Maximum
Air Temperatures	50°F (10°C)	100°F (38°C)
Water Temperatures	40°F (4.4°C)	100°F (38°C)
Remote Cond. Temps	-20°F (-29°C)	120°F (49°C)
Water Pressures	20 PSIG (1.4 bar)	80 PSIG (5.5 bar)
Electrical Voltage	-5%	+10%

Specifications and design are subject to change without notice.

C1448 - 1400lb Cube Ice Machine