



# FS0522 - 500lb Flake Ice Machine

Prodigy Plus® Flake Ice Machine



## Features & Benefits

- Sealed, maintenance-free bearings for reduced preventative maintenance and long-lasting performance
- Stainless steel evaporator and auger for maximum durability
- AutoAlert™ indicator lights for better visibility
- Operational footprint among the industry's smallest
- Unit specific QR code for quick access to service manuals, cleaning guides and warranty history
- Front-breathing - No side clearance required for flexible placement
- Smart-Board™ advanced feature module available for additional diagnostic capabilities
- Optional Vari-Smart™ ice level control allows operators to customize ice levels
- Antimicrobial protection guards internal surfaces between cleanings
- A full range of water- and energy-saving features



Sealed, maintenance-free bearings ensure maximum reliability and contribute to a long machine life



## 24 Hour Volume Production

Air Cooled			Water Cooled		
70°F/21°C 50°F/10°C	Air Water	90°F/32°C 70°F/21°C	70°F/21°C 50°F/10°C	Air Water	90°F/32°C 70°F/21°C
450/204 lb/kg		372/169 lb/kg	530/240 lb/kg		429/195 lb/kg



AutoAlert™ indicator lights and QR code for easy maintenance



## Modular Bin Options

Model Number*	Dimensions W" x D" x H"	Bin Application Capacity		Ship Weight lb/kg
		lb/kg	Finish	
B322S	22 x 34 x 44**	370/168	Metallic	140/64
B330P	30 x 34 x 31**	344/156	Poly	90/41
B530P	30 x 34 x 44**	536/244	Poly	110/50
B530S	30 x 34 x 44**	536/244	Metallic	150/68
B842S	42 x 34 x 44**	778/353	Metallic	190/86

\* Contact Scotsman for bin top requirements. \*\* Add 6" Height for bin legs.



## Flake Ice



Cools more quickly than other ice forms. Ideal for seafood and produce displays.



## Certification



## Warranty

- 3 years parts and labor on all components.
- 5 years parts on the compressor.
- Warranty valid in North, South & Central America for commercial installations.
- Contact factory for warranty in other regions.
- Residential Applications: 1 year parts and labor

FS0522 - 500lb Flake Ice Machine



# FS0522 - 500lb Flake Ice Machine

Prodigy Plus® Flake Ice Machine

FS0522 - 500lb Flake Ice Machine

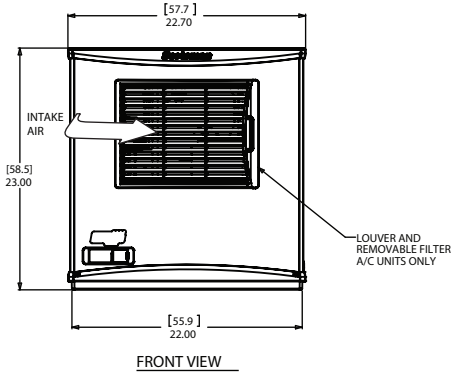
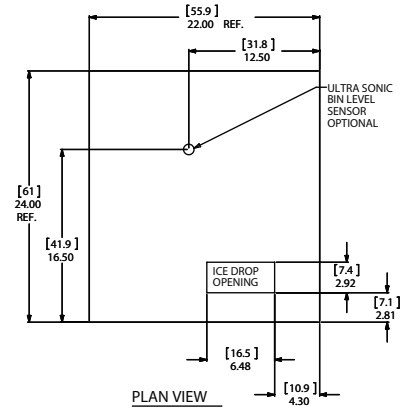
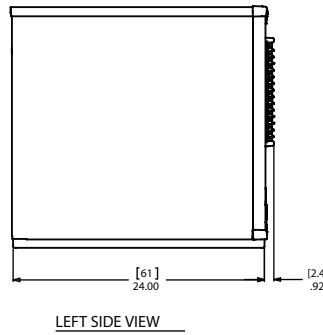
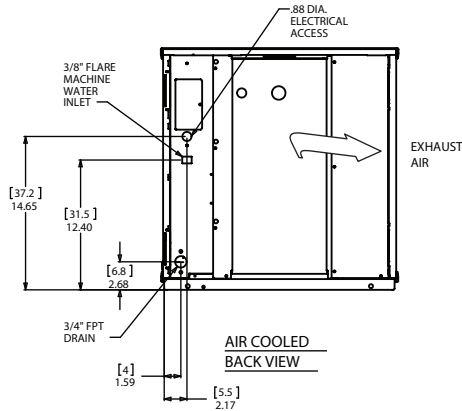
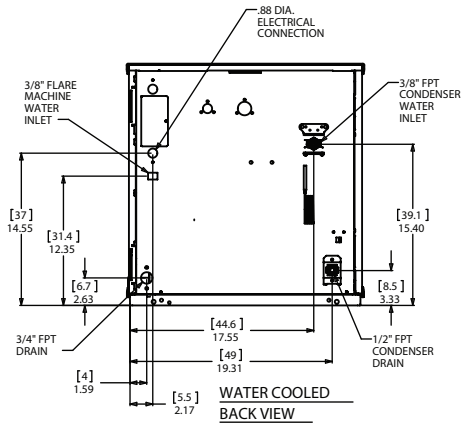

## Specifications

Model Number	Condenser Unit	Basic Electrical Volts/Hz/Phase	Max. Fuse Size or HACR Circuit Breaker (amps)	Circuit Wires	Min. Circuit Ampacity	Energy Consumption kWh/100 lb (45.4 kg) 90°F(32°C)/70°F(21°C)	Water Usage Gallons/100 lb (liters/45.4 kg)	
							Potable	Condenser 90°F(32°C)/70°F(21°C)
FS0522A-1	Air	115/60/1	20	2	12.9	6.53	12.0/45.5	-
FS0522W-1	Water	115/60/1	20	2	12.1	3.73	12.0/45.5	112/424.4



## All Models

### Dimensions (W x D x H):

Unit: 22" x 24" x 23"  
(55.9 x 61.0 x 58.4 cm)

Shipping Carton: 25.5" x 27.5" x 28.5"  
(64.8 x 69.9 x 72.4 cm)

Shipping Weight: 173lb / 78kg

BTUs per hour: 5,000

Refrigerant: R-404A



## Accessories

Model Number	Description
KVS	Vari-Smart™ Ice Level Control - Program ice bin levels to match ice needs.
KSBU	Smart-Board™ Advanced Control - Use additional operational data for fast diagnosis.
KSBU-N	Smart-Board™ Advanced Control with Network - Network capable.
KPAS	Prodigy Advanced Sustainability kit- includes KVS and KSBU-N

Scotsman recommends all ice machines have water filtration. See Scotsman water filter specification sheet for details.



## Operating Requirements

	Minimum	Maximum
Air Temperatures	50°F (10°C)	100°F (38°C)
Water Temperatures	40°F (4.4°C)	100°F (38°C)
Remote Cond. Temps	-20°F (-29°C)	120°F (49°C)
Water Pressures	20 PSIG (1.4 bar)	80 PSIG (5.5 bar)
Electrical Voltage	-5%	+10%

Specifications and design are subject to change without notice.

an Ali Group Company

- 101 Corporate Woods Parkway, Vernon Hills, IL 60061
- 1-800-SCOTSMAN Fax: 847-913-9844
- www.scotsman-ice.com customer.relations@scotsman-ice.com



The Spirit of Excellence

**Scotsman**

SIS-SS-PP-F0522 03-20

© 2020 Scotsman Ice Systems.