



Modular Remote Low Side Flake & Nugget Ice Machine

Prodigy Plus® Flake & Nugget Ice Machine



The Prodigy Plus® difference.

- AutoAlert™ indicator lights for better visibility
- Operational footprint among the industry's smallest
- Industry-exclusive QR code instantly connects users to service information and warranty history
- Front-located air filter for more efficient operation
- Self-aligning front panel for easy access to key components
- Smart-Board™ advanced feature module available for additional diagnostic capabilities
- Optional Vari-Smart™ ice level control allows operators to customize ice levels
- Antimicrobial protection guards internal surfaces between cleanings
- Sealed refrigeration system minimizes outside airborne contamination
- Inherently more energy and water efficient than cube machines



24 Hour Volume Production

Flake		Flake	
FS1222L		FS1522L	
70°F/21°C 50°F/10°C	Air Water	90°F/32°C 70°F/21°C	70°F/21°C 50°F/10°C
1180/535 lb/kg		1000/454 lb/kg	1445/655 lb/kg
			1205/547 lb/kg



24 Hour Volume Production

H² Nugget			Original Chewable Nugget				
NH0922L		NH1322L		NS0922L		NS1322L	
70°F/21°C 50°F/10°C	Air Water	90°F/32°C 70°F/21°C	70°F/21°C 50°F/10°C	Air Water	90°F/32°C 70°F/21°C	70°F/21°C 50°F/10°C	Air Water
889/403 lb/kg		766/347 lb/kg	1191/540 lb/kg	1018/462 lb/kg	1090/494 lb/kg	915/415 lb/kg	1330/603 lb/kg
							1100/499 lb/kg



Flake Ice



Cools more quickly than other ice forms. Ideal for seafood and produce displays. Perfect for presentation and preservation.



Modular Bin Options

Model Number*	Dimensions W" x D" x H"	Bin Application		Ship Weight lb/kg
		Capacity lb/kg	Finish	
B948S	48 x 34 x 44**	893/406	Metallic	209/95
BH1100BB-A	48 x 34 x 50**	1100/499	SS w/ GBB†	280/127
BH1100SS-A	48 x 34 x 50**	1100/499	Stainless Steel	280/127
BH1300BB-A	60 x 34 x 50**	1400/635	SS w/ GBB†	310/140
BH1300SS-A	60 x 34 x 50**	1400/635	Stainless Steel	310/140
BH1600BB-A	60 x 34 x 62**	1755/796	SS w/ GBB†	370/168
BH1600SS-A	60 x 34 x 62**	1755/796	Stainless Steel	370/168

*Contact Scotsman for bin top requirements. **Add 6" Height for bin legs. † Stainless steel with galvanized back & bottom.



Nugget Ice



Original Chewable Nugget
Ice Hardness Rating*: Soft = 74%
Dimensions: 7/16" x 5/16" x 3/8"

H² Nugget
Ice Hardness Rating*: Hard = 86%
Dimensions: 3/4" x 5/16" x 3/8"

*Approximation, values may vary by model



Certification



Warranty

- 3 years parts and labor on all components.
- Warranty valid in North, South & Central America for commercial installations.
- Contact factory for warranty in other regions.
- Residential Applications: 1 year parts and labor

Modular Remote Low Side Flake & Nugget Ice Machine



Modular Remote Low Side Flake & Nugget Ice Machine

Prodigy Plus® Flake & Nugget Ice Machine

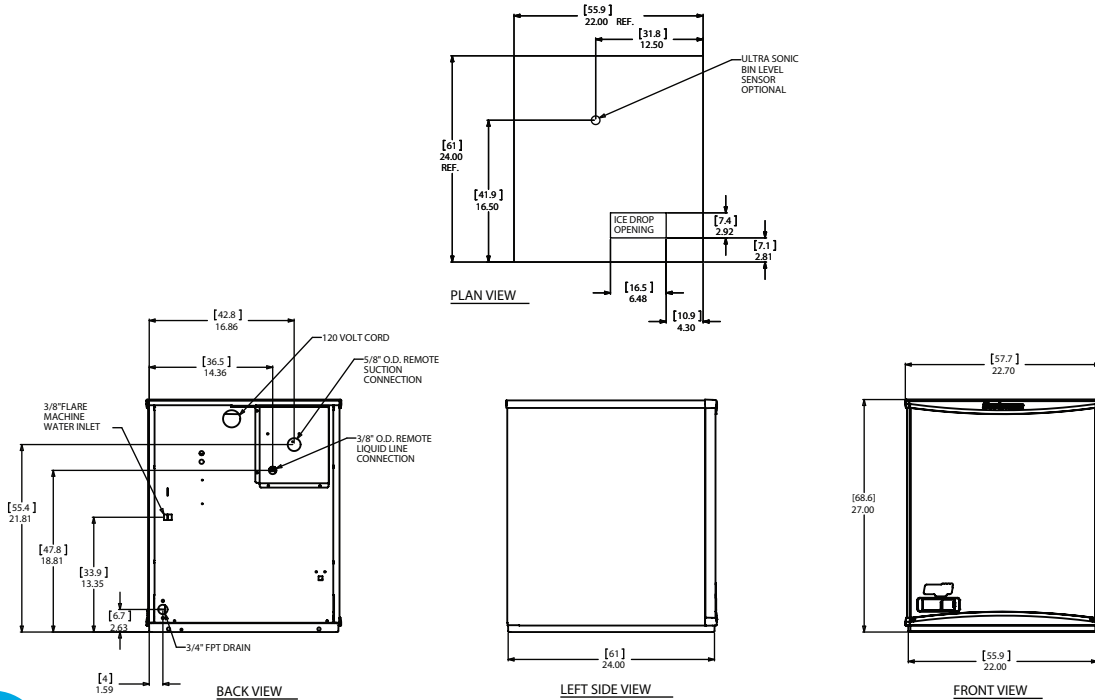

Specifications

Model Number	Condenser Unit*	Basic Electrical Volts/Hz/Phase	Max. Fuse Size (amps)	Circuit Wires	Min. Circuit Ampacity	Energy Consumption kWh/100 lb (45.4 kg) 90°F(32°C)/70°F(21°C)	Water Usage Gallons/100 lb (liters/45.4 kg)	
							Potable 90°F(32°C)	Condenser 70°F(21°C)
FS1222L-1	Remote Low Side	115/60/1	15	2	Cord	0.82	12.0/45.5	-
FS1522L-1	Remote Low Side	115/60/1	15	2	Cord	0.72	12.0/45.5	-
NH0922L-1	Remote Low Side	115/60/1	15	2	Cord	0.87	12.0/45.5	-
NH1322L-1	Remote Low Side	115/60/1	15	2	Cord	0.73	12.0/45.5	-
NS0922L-1	Remote Low Side	115/60/1	15	2	Cord	0.87	12.0/45.5	-
NS1322L-1	Remote Low Side	115/60/1	15	2	Cord	0.73	12.0/45.5	-

*Ice heads designed to operate with external condensing units (supplied by others)



All Models

Dimensions (W x D x H):

Unit:	22" x 24" x 27" (55.9 x 61.0 x 68.6 cm)
Shipping Carton:	25.5" x 27.5" x 32.5" (64.8 x 69.9 x 82.6 cm)
Shipping Weight:	FS1222L, NH0922L & NH0922L: 217lb / 98kg FS1522L, NH1322L & NS1322L: 225lb / 102kg

BTUs per hour: FS1222L, NH0922L & NH0922L:
6,000
FS1522L, NH1322L & NS1322L:
7,200

Refrigerant*: R-404A
*Refrigerant must be added at initial start-up.



Accessories

Model Number	Description
KVS	Vari-Smart™ Ice Level Control - Program ice bin levels to match ice needs.
KSBU	Smart-Board™ Advanced Control - Use additional operational data for fast diagnosis.
KSBU-N	Smart-Board™ Advanced Control with Network - Network capable.
BRTE10	10ft (3.0 m) line set, brazing required
BRTE25	25ft (7.6 m) line set, brazing required
BRTE40	40ft (12.2 m) line set, brazing required
BRTE75	75ft (22.9 m) line set, brazing required
KPAS	Prodigy Advanced Sustainability Kit - Includes KVS and KSBU - N

Scotsman recommends all ice machines have water filtration. See Scotsman water filter specification sheet for details.



Operating Requirements

	Minimum	Maximum
Air Temperatures	50°F (10°C)	100°F (38°C)
Water Temperatures	40°F (4.4°C)	100°F (38°C)
Remote Cond. Temps	-20°F (-29°C)	120°F (49°C)
Water Pressures	20 PSIG (1.4 bar)	80 PSIG (5.5 bar)
Electrical Voltage	-5%	+10%

Specifications and design are subject to change without notice.

Modular Remote Low Side Flake & Nugget Ice Machine

an Ali Group Company



The Spirit of Excellence

