



N0922 - 900lb Nugget Ice Machine

Prodigy Plus® Nugget Ice Machine

Features & Benefits

- Available in softer, Original Chewable Nugget Ice and harder, H² Nugget Ice
- Sealed, maintenance-free bearings for reduced preventative maintenance and long-lasting performance
- Stainless steel evaporator and auger for maximum durability
- AutoAlert™ indicator lights for better visibility
- Operational footprint among the industry's smallest
- Unit specific QR code for quick access to service manuals, cleaning guides and warranty history
- Front-breathing - No side clearance required for flexible placement
- Smart-Board™ advanced feature module available for additional diagnostic capabilities
- Optional Vari-Smart™ ice level control allows operators to customize ice levels
- Antimicrobial protection guards internal surfaces between cleanings
- Sealed refrigeration system minimizes outside airborne contamination
- Inherently more energy and water efficient than cube machines



24 Hour Volume Production

Original Chewable Nugget

Air Cooled		Remote Cooled		Water Cooled	
70°F/21°C	Air	90°F/32°C	70°F/21°C	Air	90°F/32°C
50°F/10°C	Water	70°F/21°C	50°F/10°C	Water	70°F/21°C
956/438		784/353	1044/474	781/352	1094/496
lb/kg		lb/kg	lb/kg	lb/kg	lb/kg



Sealed, maintenance-free bearings ensure maximum reliability and contribute to a long machine life



24 Hour Volume Production

H² Nugget

Air Cooled		Remote Cooled		Water Cooled	
70°F/21°C	Air	90°F/32°C	70°F/21°C	Air	90°F/32°C
50°F/10°C	Water	70°F/21°C	50°F/10°C	Water	70°F/21°C
952/432		740/336	896/406	758/344	908/412
lb/kg		lb/kg	lb/kg	lb/kg	lb/kg

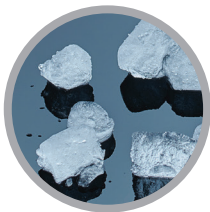

Available in softer, Original Chewable Nugget Ice or harder, H² Nugget Ice



Modular Bin & Dispenser Options

Model Number*	Dimensions W" x D" x H"	Bin Application		Ship Weight lb/kg
		Capacity lb/kg	Finish	
B530P	30 x 34 x 44**	536/244	Poly	110/50
B530S	30 x 34 x 44**	536/244	Metallic	150/68
B842S	42 x 34 x 44**	778/353	Metallic	190/86
B948S	48 x 34 x 44**	893/406	Metallic	209/95
ID200	30 x 30 x 35.625	-	Stainless Steel	183/83
ID250	30 x 30 x 39.625	-	Stainless Steel	188/85

*Contact Scotsman for bin top requirements. **Add 6" Height for bin legs.
† Stainless steel with galvanized back & bottom.



Nugget Ice

Original Chewable Nugget
Ice Hardness Rating*: Soft = 74%
Dimensions: 7/16" x 5/16" x 3/8"



H² Nugget
Ice Hardness Rating*: Hard = 86%
Dimensions: 3/4" x 5/16" x 3/8"



Certification



Warranty

- 3 years parts and labor on all components.
- 5 years parts on the compressor.
- Warranty valid in North, South & Central America for commercial installations.
- Contact factory for warranty in other regions.
- Residential Applications: 1 year parts and labor

N0922 - 900lb Nugget Ice Machine



N0922 - 900lb Nugget Ice Machine

Prodigy Plus® Nugget Ice Machine

N0922 - 900lb Nugget Ice Machine

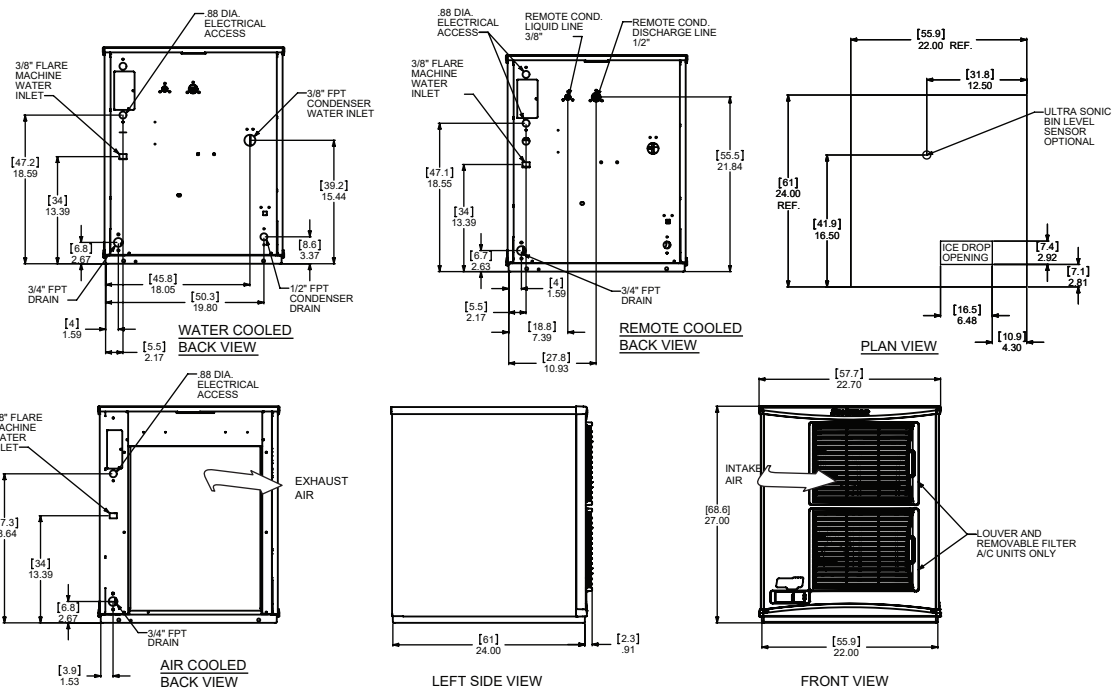

Specifications

Model Number	Condenser Unit	Basic Electrical Volts/Hz/Phase	Max. Fuse Size or HACR Circuit Breaker (amps)	Circuit Wires	Min. Circuit Ampacity	Energy Consumption kWh/100 lb (45.4 kg) 90°F(32°C)/70°F(21°C)	Water Usage Gallons/100 lb (liters/45.4 kg)		Energy Star®	
							Potable 90°F(32°C)/70°F(21°C)	Condenser 125/473.2		
Nugget Type: Soft or Hard										
soft	NS0922A-1	Air	115/60/1	20	2	16.7	3.65	12.0/45.5	-	✓
	NS0922A-32	Air	208-230/60/1	15	2	11.9	3.65	12.0/45.5	-	✓
	NS0922R-1	Remote	115/60/1	20	2	17.4	3.82	12.0/45.5	-	
	NS0922R-32	Remote	208-230/60/1	15	2	11.7	3.82	12.0/45.5	-	
	NS0922W-3	Water	208-230/60/3	15	3	8.0	3.09	12.0/45.5	125/473.2	
	NS0922W-32	Water	208-230/60/1	15	2	10.7	3.09	12.0/45.5	125/473.2	
hard	NH0922A-1	Air	115/60/1	20	2	16.7	4.01	12.0/45.5	-	
	NH0922A-32	Air	208-230/60/1	15	2	11.9	4.01	12.0/45.5	-	
	NH0922R-1	Remote	115/60/1	20	2	17.4	4.24	12.0/45.5	-	
	NH0922R-32	Remote	208-230/60/1	15	2	11.7	4.24	12.0/45.5	-	
	NS0922W-32	Water	208-230/60/1	15	2	10.7	3.14	12.0/45.5	136/515	



All Models

Dimensions (W x D x H):

Unit: **Individual**
22.9" x 24" x 27"
(58.2 x 61.0 x 68.6 cm)

Side by Side
45.8" x 24" x 27"
(116.3 x 61.0 x 68.6 cm)

Shipping Carton: 25.5" x 27.5" x 32.5"
(64.8 x 69.9 x 82.6 cm)

Shipping Weight: 210 lb / 95 kg BTUs per hour: 10,500

Refrigerant: R-404A



Accessories

Model Number	Description
KVS	Vari-Smart™ Ice Level Control - Program ice bin levels to match ice needs.
KSBU	Smart-Board™ Advanced Control - Use additional operational data for fast diagnosis.
KSBU-N	Smart-Board™ Advanced Control with Network - Network capable.
ERC311-32	Remote condenser for N0922R, 208-230V/60/1
ERC111-1	Remote condenser for N0922R-1, 115V/60/1
BRTE10	Line set, 10ft, brazing required.
BRTE25	Line set, 25ft, brazing required.
BRTE40	Line set, 40ft, brazing required.
BRTE75	Line set, 75ft, brazing required.
KPAS	Prodigy Advanced Sustainability Kit - Includes KVS and KSBU - N

Scotsman recommends all ice machines have water filtration. See Scotsman water filter specification sheet for details.



Operating Requirements

	Minimum	Maximum
Air Temperatures	50°F (10°C)	100°F (38°C)
Water Temperatures	40°F (4.4°C)	100°F (38°C)
Remote Cond. Temps	-20°F (-29°C)	120°F (49°C)
Water Pressures	20 PSIG (1.4 bar)	80 PSIG (5.5 bar)
Electrical Voltage	-5%	+10%

Specifications and design are subject to change without notice.

• 101 Corporate Woods Parkway, Vernon Hills, IL 60061 •

• 1-800-SCOTSMAN • Fax: 847-913-9844 • www.scotsman-ice.com • customer.relations@scotsman-ice.com •

Scotsman®